



Cat. Nos. 0571 Series Gas Tank Vent with Swivel Elbow

INSTALLATION INSTRUCTIONS

Read all directions before proceeding.

- 1). On gasoline tanks, vent must be installed in accordance with U.S.C.G. Safety Standards for Boat Gasoline Fuel Systems, #33CFR183 and A.B.Y.C. Standard H-24.
- 2). Locate mounting surface with thickness up to 3/4 inch maximum.
- 3). Drill 3/4 inch diameter hole in mounting surface.
- 4). Move the nut and washer toward bend in elbow.
- 5). Remove vent head and splash guard assembly. Insert threaded end of elbow through mounting hole, and apply bedding compound around outside of mounting hole.
- 6). Remove splash guard from vent head, and attach vent head to threaded portion of elbow, tightening securely to insure proper seal. NOTE: Nut and washer must be moved back far enough such that vent head bottoms out on the threaded end of the elbow (not the mounting surface) to insure proper seal.
- 7). Align elbow to suitable orientation, with regard to vent hose path.
- 8). Tighten nut and washer to inside of mounting surface.
- 9). Attach vent hose to barbed end of elbow, and secure with a hose clamp.
- 10). To pressure test fuel system, remove splash guard and attach optional orange test cap (Cat. No. 0101).
- 11). Remove test cap and reattach splash guard after pressure testing.

0571INS1
07/22

(1). American Boat & Yacht Council, Inc.
613 Third Street, Suite 10
Annapolis, MD 21403

(2). U.S. Coast Guard
Washington, D.C. 20593
(or your local C.G. office)

PERKO®

16490 N.W. 13th Ave.
Miami, FL 33169-5707
www.perko.com

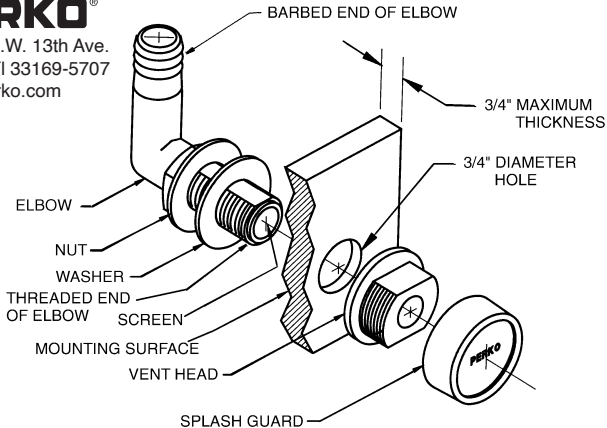

(OVER)